

# Schlüter®-BEKOTEC-EN 12 FK

## Bonded covering assembly

Curl-resistant, thin-layer bonded covering assembly for renovations

# 9.5

Product data sheet

### Application and Function

**Schlüter®-BEKOTEC-EN 12 FK** is a reliable covering assembly system for crack-free and functionally safe floating screeds and heated screeds with coverings made of ceramic tiles, natural stone, and other materials.

The floating system is installed directly on load-bearing, weight-distributing substrates such as concrete or existing wooden floor structures, using the thin-bed method. The thin-bed screed must be manufacturer recommended for the corresponding substrate. The suitability of the substrate for heating purposes (movement joints, edge strips etc.) must be verified. The system is based on the studded polystyrene screed panel Schlüter®-BEKOTEC-EN 12 FK with an anchoring fleece on the underside. The studded screed panel is directly installed onto suitable weight-distributing substrates as a bonded assembly, using the thin-bed method. The geometry of the studded panel Schlüter®-BEKOTEC-EN 12 FK results in a minimum screed thickness of 20 mm between the studs and 8 mm above them. The studs are designed to hold the heating pipes of the system (diameter: 10 mm) in a grid pattern of 50 mm in order to create heated screeds.

The floor heating system is easily adjustable and ideally suited for use with low temperatures, since the screed volume to be heated or cooled is relatively small (approx. 40 kg/m<sup>2</sup> ± 20 l /m<sup>2</sup> with 8 mm coverage). The curing stresses that occur in the screed due to shrinkage are absorbed by the studded pattern, thus controlling deformations such as curling. It is therefore unnecessary to install dummy joints or movement joints in the screed. As soon as the cement screed is ready to support weight, the uncoupling mat

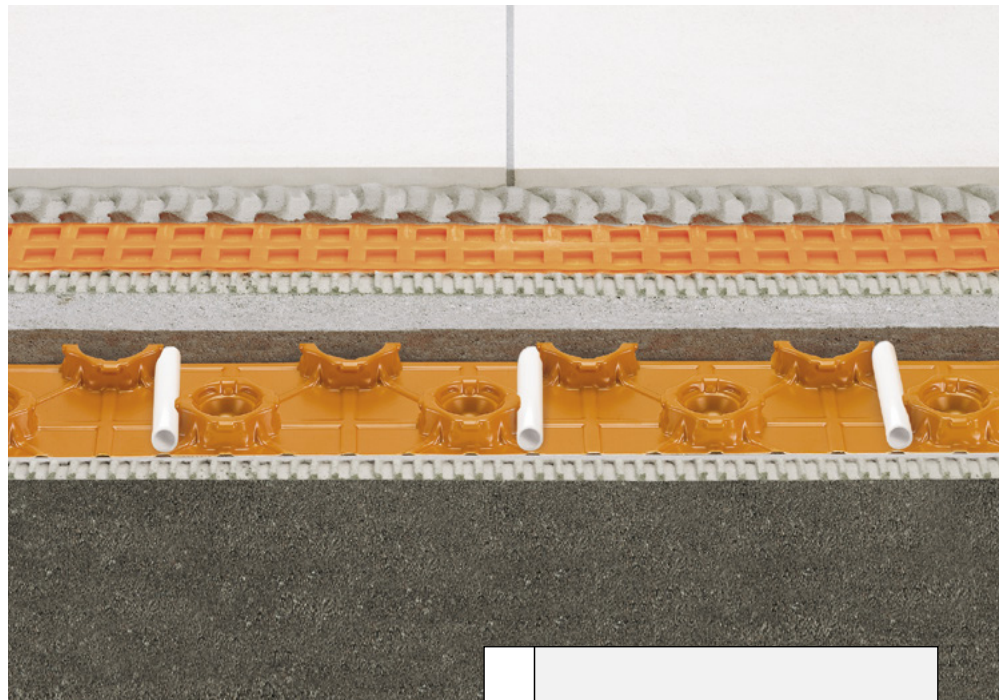

Schlüter®-DITRA 25 can be installed (calcium sulfate screed < 2 CM-%). Ceramic or natural stone tiles are then installed directly over this layer, using the thin-bed method. Movement joints in the covering layer are created using Schlüter®-DILEX according to industry guidelines. Cover materials that are not susceptible to cracking, such as parquet or carpeting, can be directly installed over the screed as soon as it reaches the necessary residual moisture level for the corresponding covering. See the Technical Manual for further details.

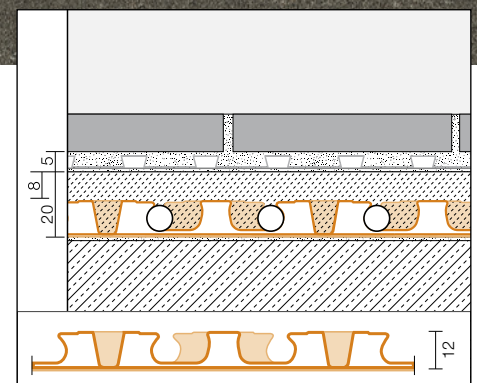



## Material

Schlüter®-BEKOTEC-EN 12 FK is made of a high-impact polystyrene deep-drawn foil and is suitable for use with conventional cement screeds of strength class CT-C25-F4 (ZE 20) or calcium sulfate screed CA-C25-F4 (AE 20) as well as flowing screed.

## Installation

1. Schlüter®-BEKOTEC-EN 12 FK is a bonded assembly that is installed on a sufficiently load-bearing and level substrate in the thin-bed method with the anchoring fleece on the underside. The substrate must be level, ready to support weight, and free of all substances that may weaken the bond. Any levelling must be completed prior to installing Schlüter®-BEKOTEC-EN 12 FK.

The adhesive used for bonding Schlüter®-BEKOTEC-EN 12 FK must be selected to suit the substrate type. The adhesive must bond well with the substrate and mechanically set in the anchoring fleece of Schlüter®-BEKOTEC-EN 12 FK. Standard dry-set mortars are suitable for most substrates. Check for any incompatibilities of materials. 1. Apply thin-bed mortar on the substrate with a notched trowel (recommended size: 6 x 6 mm).

2. Adhere the 5 mm edge strip Schlüter®-BEKOTEC-BRS 505 KSF in places where the covering adjoins walls and other construction elements. The edge strip features an adhesive segment on the bottom for secure attachment. The adhesion on the substrate and the pre-tensioning of the integrated foil leg push the edge strip toward the wall. When the studded Schlüter®-BEKOTEC panel is adhered over the adhesive strip, the panel is permanently adhered to the substrate and flowing screed can no longer get beneath the panel.
3. Fully embed the anchoring fleece of Schlüter®-BEKOTEC-EN 12 FK in the adhesive and observe the curing times of all materials. The studded screed panels Schlüter®-BEKOTEC-EN 12 FK must be precisely cut to size in the perimeter areas. The Schlüter®-BEKOTEC panels are connected by

overlapping a row of studs as shown in the image.

In door transition areas and near distributor boxes, the smooth levelling panel Schlüter®-BEKOTEC-ENFGK may be used to simplify the pipe installation. This panel is used underneath the studded panels and is adhered with double-sided adhesive strips. If necessary, apply the included double-sided adhesive tape on the surface of the levelling panel. The self-adhesive pipe clamping strip Schlüter®-BEKOTEC ZRKL 10/12 allows for precise routing of pipes in these areas.

4. To create a Schlüter®-BEKOTEC-THERM ceramic thermal comfort floor, the system pipes with a diameter of 10 mm are now clamped between the cutback studs. The spacing of the pipes must be determined on the basis of the required heating output, as shown in the Schlüter®-BEKOTEC heating diagrams.
5. As part of the screed installation, cement screed with strength class CT-C25-F4 (ZE 20) or calcium sulfate screed CA-C25-F4 (AE 20) is installed with a minimum screed cover of 8 mm over the studded panels. The flexural strength of the screed may not exceed F5. The screed thickness may be increased to max. 15 mm above the studs for levelling. To avoid sound transmission between individual rooms, the screed should be separated in these places, using the expansion joint profile Schlüter®-DILEX-DFFP.
6. As soon as the cement screed is ready to support weight, the uncoupling mat Schlüter®-DITRA 25 may be installed in accordance with the manufacturer's recommendations (see product data sheet 6.1). Calcium sulfate screeds may be covered with Schlüter®-DITRA 25 as soon as they have reached a residual moisture level of < 2 CM-%.
7. Ceramic tile or natural stone can be directly installed on top of Schlüter®-DITRA 25, using the thin-bed method. The ceramic covering must be divided into fields with movement joints above Schlüter®-DITRA 25 in accordance with the applicable regulations. We recommend the profiles Schlüter®-DILEX-BWB, -BWS, -KS or AKWS for creating movement joints (see

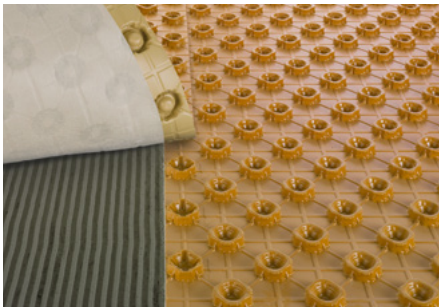

Step 3.

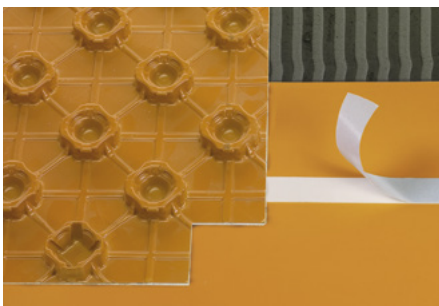

Step 3.



- product information sheets 4.6, 4.7, 4.8 and 4.18).
8. Our corner movement profiles Schlüter®-DILEX-EK or -RF (see product data sheet 4.14) can be used as a flexible edge joint in wall to floor transition areas. The protruding sections of the Schlüter®-BEKOTEC-BRS edge strip should first be trimmed.
  9. The Schlüter®-BEKOTEC-THERM ceramic thermal comfort floor is ready for heating just seven days after the completion of the cover assembly. Increase the supply temperature by a maximum of 5 °C a day to reach the desired operating temperature, starting from 25 °C water temperature.
  10. All other covering materials that are not susceptible to cracking (e.g., parquet, carpeting or synthetic coverings) can be directly installed over the Schlüter®-BEKOTEC screed without the Schlüter®-DITRA 25 uncoupling mat. The height of the screed must be adjusted to the corresponding material thickness. In addition to the applicable installation guidelines, note the permissible residual moisture level of the screed for the selected covering material.
3. Working area: 1.1 x 0.7 m = 0.77 m<sup>2</sup>  
Panel height: 12 mm
  4. Packaging: 10 units/box = 7.7 m<sup>2</sup>  
Box size is approx.  
1160 x 800 x 80 mm

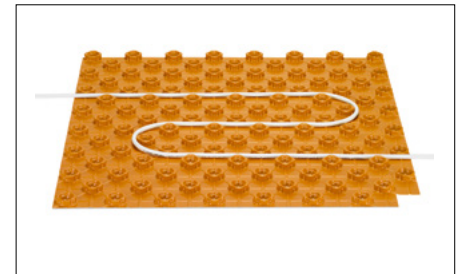

## Notes

Schlüter®-BEKOTEC-EN 12 FK, -ENFGK, and -BRS are non-rotting and require no special maintenance or care. Before and during the installation of the screed, the studded screed panel may need to be protected from mechanical damage with suitable measures, such as laying out timber boards.

## Technical data

1. Stud size: approx. 44 mm  
Grid spacing: 50, 100, 150 mm ...  
Diameter of system heating pipes:  
10 mm  
The studs have a cutback design to securely keep heating pipes in place without the need for clamps.
2. Connections:  
The studded panels are connected by overlapping a row of studs and clicking the panels together.



## Supplementary system products

### Levelling panel

The levelling panel Schlüter®-BEKOTEC-ENF GK is installed in door transition areas and in the area of heating circuit distributors to simplify connections and minimize cutting waste. It is made of smooth polystyrene foil material. If necessary, the studded panel can be attached by placing additional pieces of double-sided adhesive tape Schlüter®-BEKOTEC-BTZ DK 66 on the levelling panel.

Dimensions: 1100 x 700 mm

### Pipe clamping strip

Schlüter®-BEKOTEC-ZRKL 10/12 is a pipe clamping strip for securing the pipes on the levelling panel. The clamping strips are self-adhesive to allow for permanent attachment on the levelling panel.

Length: 80 cm

### Double-sided adhesive tape

Schlüter®-BEKOTEC-BTZDK66 is a double-sided adhesive tape for adhering the studded panel to the levelling panel or to the substrate if necessary.

Roll: 66 m, height: 30 mm, thickness: 1 mm

### Edge strip

Schlüter®-BEKOTEC-BRS 505 KSF is an edge strip of closed-cell polyethylene foam with an integrated foil leg that features an adhesive strip on the underside for attachment. The adhesion on the substrate and the pre-tensioning of the integrated foil leg push the edge strip toward the wall. When the studded Schlüter®-BEKOTEC panel is laid on top of the adhesive strip, the panel is permanently adhered to the substrate and flowing screed can no longer get beneath the panel.

Roll: 25 m, height: 5 cm, thickness: 5 mm

### Expansion joint profile

Schlüter®-DILEX-DFP is an expansion joint profile for installation in door transition areas to prevent sound bridges. Thanks to the bilateral coating and the self-adhesive strip, straight-line installation is very easy.

Length: 1.00 m, height: 60 / 80 / 100 mm, thickness 10 mm

Length: 2.50 m, height: 100 mm, thickness: 10 mm

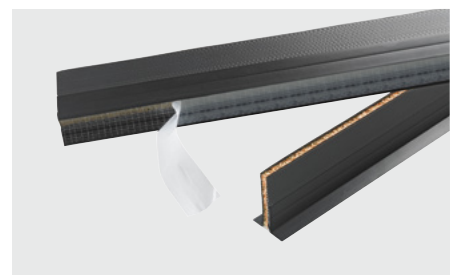
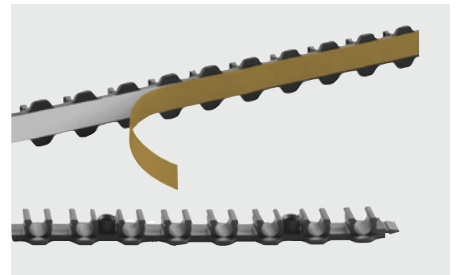



## Advantages of the Schlüter®-BEKOTEC system

### ■ Warranty:

Schlüter-Systems offer a five-year warranty for the life of the covering assembly, provided all installation instructions were observed and the covering is used as intended.

### ■ Crack-free covering:

The Schlüter®-BEKOTEC system is designed to reduce shearing tensions in the screed within the grid of the studded panel. No construction reinforcement is required.

### ■ Curl-resistant construction:

The cover assembly of the Schlüter®-BEKOTEC system is free of inherent stresses. Consequently, curling is virtually impossible to occur in the area. This is especially applicable in the presence of temperature fluctuations, for example with heated screeds.

### ■ Joint-free screed:

The regular patterns of the Schlüter®-BEKOTEC system evenly reduce tensions in the screed, which allows for constructing the screed without movement joints.

### ■ Movement joints in the joint pattern of the tile or stone covering:

With the Schlüter®-BEKOTEC system, the design of movement joints can match the joint pattern of the tiles or stone covering, since it is not necessary to continue construction joints from the screed into the surface covering. The applicable regulations for the dimensions of the covering pattern must be observed.

### ■ Short construction time:

As soon as the screed produced with the Schlüter®-BEKOTEC system is able to support weight, coverings of ceramic tile, natural or artificial stone can be directly installed on top of the Schlüter®-DITRA 25 membrane. Ceramic thermal comfort floors are ready for heating only 7 days after the completion of the cover assembly.

### ■ Material savings:

Just 40 kg/m<sup>2</sup> ± 20 l /m<sup>2</sup> of screed are required with a screed cover of 8 mm.

### ■ Fast-reacting heated floor assembly:

Compared to conventional heated screeds, cover assemblies installed with a Schlüter®-BEKOTEC system react much faster to temperature changes, since the volume to be heated or cooled is much smaller. Consequently, the heated floor system is particularly suitable for operation at low temperatures.

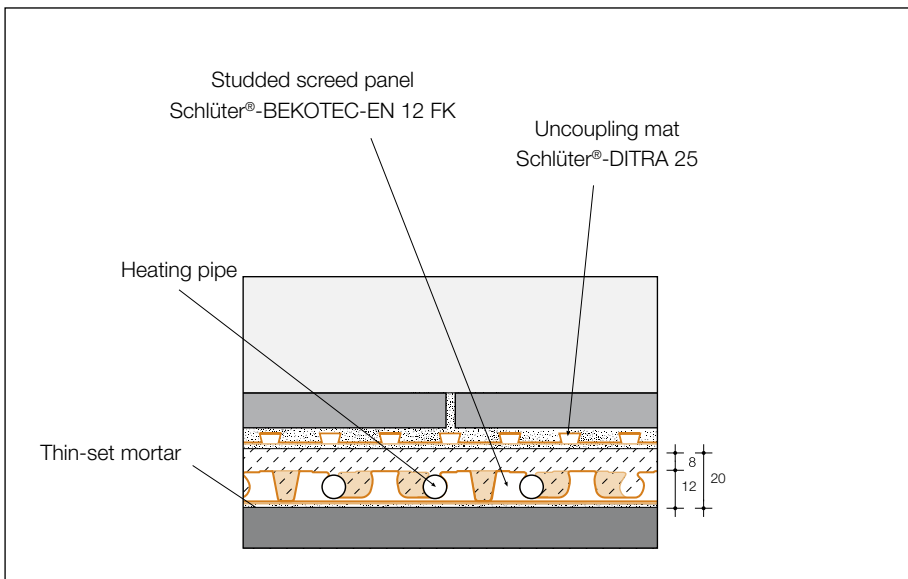

Heating or impact sound insulation panel as specified by the architect

### Product Overview:

#### Schlüter®-BEKOTEC-EN 12 FK

Studded screed panel	Dimensions	Packaging
EN12 FK	1.1 x 0.7 m = 0.77 m <sup>2</sup> working area	10 Panels (7.7 m <sup>2</sup> ) / box

#### Schlüter®-BEKOTEC-BRS

Edge strip	Dimensions	Roll
BRS 505 KSF	5 mm x 50 mm	25 m

#### Schlüter®-BEKOTEC-ENFGK

Levelling panel	Dimensions
EN 12 FGK	1100 x 700 mm

#### Schlüter®-BEKOTEC-ZRKL

Pipe clamping strip	Dimensions
BTZRKL 1012	800 mm x 25 mm

#### Schlüter®-BEKOTEC-ZDK

Double-sided adhesive tape	Dimensions	Roll
BTZDK66	30 mm x 1 mm	66 m

#### Schlüter®-DILEX-DFP

DFP = Expansion joint profile Supplied length: 1.00 m

H = mm	Packaging
60	20 units
80	20 units
100	20 units

#### Schlüter®-DILEX-DFP

DFP = Expansion joint profile Supplied length: 2.50 m

H = mm	Packaging
100	40 units



### Text template for tenders:

\_\_\_\_\_m<sup>2</sup> Schlüter®-BEKOTEC-EN 12 FK , as a studded screed panel made of polystyrene deep-drawing foil with cutback 12 mm studs and an anchoring fleece laminated on the back-side. Heating pipes can be installed in grids with spacing of 50, 100, 150 ... mm. The outer row of studs can be used to connect panels with a working area of 1.1 m x 0.7 m = 0.77 m<sup>2</sup>, to be professionally installed, including custom cuts in the edge area, if applicable with the levelling panel Schlüter®-BEKOTEC-ENFGK.

The installation instructions of the manufacturer must be observed.

Material: \_\_\_\_\_ .... /m<sup>2</sup>  
 Labour: \_\_\_\_\_ .... /m<sup>2</sup>  
 Total price: \_\_\_\_\_ .... /m<sup>2</sup>

\_\_\_\_\_linear metres of Schlüter®-BEKOTEC-BRS 505 KSF as an edge insulation strip of closed-cell polyethylene foam, 5 mm thick, 50 mm high, with self-adhesive support strip at the bottom, to be installed at floor to wall transitions or fixed construction elements. The adhesive strip of the edge strip must be installed below the studded screed panel and joined to the underside of the studded panel.

The installation instructions of the manufacturer must be observed.

Material: \_\_\_\_\_ .... /m  
 Labour: \_\_\_\_\_ .... /m  
 Total price: \_\_\_\_\_ .... /m

\_\_\_\_\_linear metres of Schlüter®-DILEX DFP as an expansion joint profile of closed-cell polyethylene foam, with lateral hard plastic coating, 10 mm thick, for installation in door transition areas with self-adhesive base.

The installation instructions of the manufacturer must be observed.

Height:  60 mm  80 mm  100 mm  
 Material: \_\_\_\_\_ .... /m  
 Labour: \_\_\_\_\_ .... /m  
 Total price: \_\_\_\_\_ .... /m

\_\_\_\_\_linear metres of Schlüter®-THERM-HR heating pipe 14 x 2 mm, quality monitored, of high quality PE-RT plastic with high temperature resistance, very flexible, for optimal installation in the Schlüter®-BEKOTEC studded screed panel, to be supplied and professionally installed while observing the manufacturer's instructions.

The installation instructions of the manufacturer must be observed.

Make: \_\_\_\_\_ Art. no.: \_\_\_\_\_  
 Material: \_\_\_\_\_ .... /m  
 Labour: \_\_\_\_\_ .... /m  
 Total price: \_\_\_\_\_ .... /m

\_\_\_\_\_m<sup>2</sup>

- Cement screed of strength class CT-C25-F4 (ZE 20)
  - conventional installation
  - poured screed
- Calcium sulfate screed of strength class CA-C25-F4 (AE 20)
  - conventional installation
  - flowing screed

or equivalent with a minimum screed cover of 8 mm over the studs of the polystyrene panel Schlüter®-BEKOTEC-EN, to be installed without joints, compacted, and smoothed. Sound bridges at wall connections or construction elements as well as in door transition areas must be avoided. The installation instructions of the manufacturer must be observed.

Material: \_\_\_\_\_ .... /m<sup>2</sup>  
 Labour: \_\_\_\_\_ .... /m<sup>2</sup>  
 Total price: \_\_\_\_\_ .... /m<sup>2</sup>

\_\_\_\_\_m<sup>2</sup> Schlüter®-DITRA 25 as a tension-neutralizing and crack-bridging uncoupling mat made of polyethylene foil with a cutback dovetail rib structure and anchoring fleece laminated on the underside, to be supplied and professionally installed on load-bearing Schlüter®-BEKOTEC screed, using dry-set thin-bed mortar.

Install Schlüter®-DITRA as an additional bonded waterproofing assembly. This requires the professional waterproofing of all connections at pipe sleeves, floor drains, wall fixtures and abutting seams with Schlüter®-KERDI-KEBA. The resulting additional cost is to be  included in the unit prices,  invoiced separately.

The installation instructions of the manufacturer must be observed.

Material: \_\_\_\_\_ .... /m<sup>2</sup>  
 Labour: \_\_\_\_\_ .... /m<sup>2</sup>  
 Total price: \_\_\_\_\_ .... /m<sup>2</sup>



\_\_\_\_\_linear metres of Schlüter®-DILEX-KS as a movement joint profile with lateral metal profiles of

- EKS N = stainless steel
- EKS N V4A = stainless steel 1.4404 (V4A)
- AKS N = aluminum

with trapezoid-perforated anchoring legs and an 11 mm movement zone of synthetic rubber installed in a U-shaped profile chamber, to be supplied and professionally installed as part of the tile installation, while observing the manufacturer's instructions.

Colour: \_\_\_\_\_

Profile height: \_\_\_\_\_

Material: \_\_\_\_\_ .... /m

Labour: \_\_\_\_\_ .... /m

Total price: \_\_\_\_\_ .... /m

\_\_\_\_\_ linear metres of movement joint profile Schlüter®-DILEX-BWB as a movement joint profile with lateral trapezoid-perforated anchoring angles of recycled rigid PVC and an approx. 5 mm flexible movement zone of soft CPE, to be supplied and professionally installed as part of the tile installation, while observing the manufacturer's instructions.

Colour: \_\_\_\_\_

Profile height: \_\_\_\_\_

Material: \_\_\_\_\_ .... /m

Labour: \_\_\_\_\_ .... /m

Total price: \_\_\_\_\_ .... /m

\_\_\_\_\_linear metres of Schlüter®-DILEX-BWS as a movement joint profile with lateral trapezoid-perforated anchoring angles of recycled rigid PVC and an approx. 5 mm flexible movement zone of soft CPE, to be supplied and professionally installed as part of the tile installation, while observing the manufacturer's instructions.

Colour: \_\_\_\_\_

Profile height: \_\_\_\_\_

Material: \_\_\_\_\_ .... /m

Labour: \_\_\_\_\_ .... /m

Total price: \_\_\_\_\_ .... /m

\_\_\_\_\_linear metres of Schlüter®-DILEX-AKWS as a movement joint profile with lateral aluminum profiles with trapezoid-perforated anchoring legs and a profile chamber for insertion of a 6 mm movement zone of synthetic material, to be supplied and professionally installed as part of the tile installation, while observing the manufacturer's instructions.

Profile height:  
(depending on tile thickness): \_\_\_\_\_ mm

Colour: \_\_\_\_\_

Item no: \_\_\_\_\_

Material: \_\_\_\_\_ .... /m

Labour: \_\_\_\_\_ .... /m

Total price: \_\_\_\_\_ .... /m

\_\_\_\_\_linear metres of Schlüter®-DILEX-EK as a two part corner movement profile with a tongue and groove connection for permanently flexible joints at floor to wall transitions with trapezoid perforated rigid PVC anchoring legs and soft CPE expansion zone, suitable for absorbing vertical deformations up to 8 mm, to be supplied and professionally installed, while observing the manufacturer's instructions.

Colour: \_\_\_\_\_

Profile height: \_\_\_\_\_

Material: \_\_\_\_\_ .... /m

Labour: \_\_\_\_\_ .... /m

Total price: \_\_\_\_\_ .... /m

\_\_\_\_\_linear metres of Schlüter®-DILEX-RF as a two-part corner profile with a tongue and groove connection for permanent flexible corner joints between floor and skirting or wall tiles, featuring trapezoid perforated anchoring legs made of rigid PVC and a movement zone made of soft CPE, suitable for accepting vertical movements up to approximately 8 mm, and install according to the manufacturer's specifications.

Profile height U: \_\_\_\_\_ mm

Profile height O: \_\_\_\_\_ mm

Colour: \_\_\_\_\_

Item no: \_\_\_\_\_

Material: \_\_\_\_\_ .... /m

Labour: \_\_\_\_\_ .... /m

Total price: \_\_\_\_\_ .... /m

\_\_\_\_\_m<sup>2</sup>

- Tiles
- Natural stone
- Agglomerate stone

of dimensions .....cm x .....cm

Make: \_\_\_\_\_ Art. no.: \_\_\_\_\_

to be supplied and professionally installed using the thin-bed method in dry set mortar over Schlüter®-DITRA, complete with grouting after the curing of the thin-bed mortar. The installation instructions of the manufacturers must be observed.

Material: \_\_\_\_\_ .... /m<sup>2</sup>

Labour: \_\_\_\_\_ .... /m<sup>2</sup>

Total price: \_\_\_\_\_ .... /m<sup>2</sup>